

**STRAIGHT BULKHEAD JACK,
CRIMP OR SOLDER TYPE - CABLE 2.6/50 D**

R125.304.001

Series : SMA

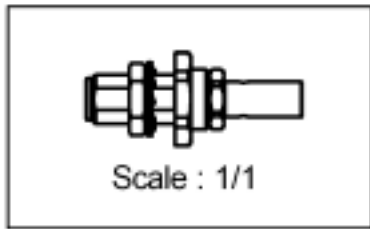
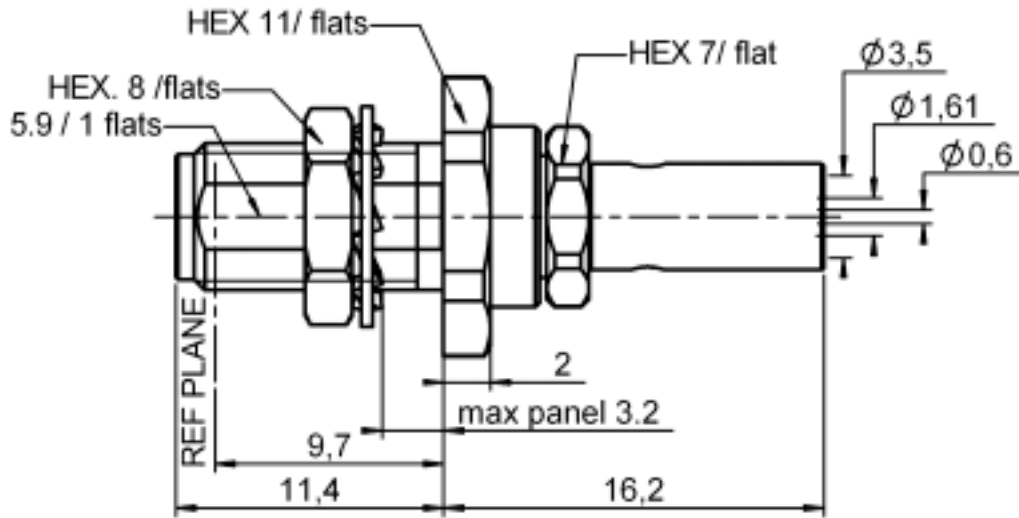

PANEL CUT OUT



mm		
	Maxi	mini
A	6.5	6.4
B	6.15	6.0

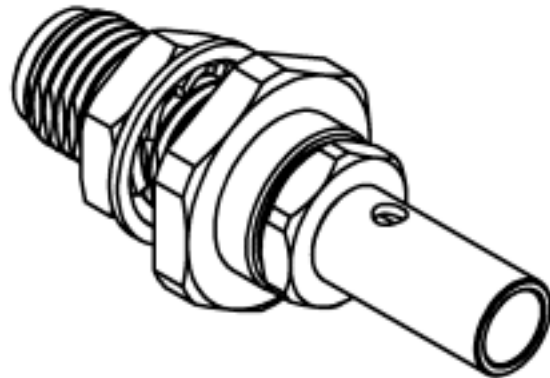

All dimensions are in mm.



COMPONENTS	MATERIALS	PLATINGS (µm)
BODY	STAINLESS STEEL	PASSIVATED .
CENTER CONTACT	BERYLLIUM COPPER	GOLD 1.3 OVER NICKEL 2
OUTER CONTACT	-	-
INSULATOR	PTFE	-
GASKET	-	-
OTHERS PARTS	BRASS	NICKEL 2
-	-	-
-	-	-

Issue : 0323 A

In the effort to improve our products, we reserve the right to make changes judged to be necessary.



**STRAIGHT BULKHEAD JACK,
CRIMP OR SOLDER TYPE - CABLE 2.6/50 D**

R125.304.001

Series : SMA

PACKAGING

Standard	Unit	Other
1	-	Contact us

SPECIFICATION

ELECTRICAL CHARACTERISTICS

Impedance		50 Ω
Frequency		0-12.4 GHz
VSWR	1.15 +	0.020 x F(GHz) Maxi
Insertion loss		0.06 √F(GHz) dB Maxi
RF leakage	- (60 - F(GHz)) dB Maxi
Voltage rating		250 Veff Maxi
Dielectric withstanding voltage		750 Veff mini
Insulation resistance		5000 MΩ mini

CABLE ASSEMBLY

Stripping	a	b	c	d	e	f
mm	3.50	7.00	13.5	0.00	10.0	0.00

Assembly instruction : **Crimp 10**

Recommended cable(s)
RD 316
K02252D

Characteristics indicated on this data sheet are those that can be achieved with the highest performance cable. Intrinsic limitations of the cable may diminish the performance of the assembly

Cable retention

- pull off **110** N mini
- torque **NA** N.cm

MECHANICAL CHARACTERISTICS

Center contact retention		
Axial force – Mating end	27	N mini
Axial force – Opposite end	27	N mini
Torque	NA	N.cm mini

Recommended torque		
Mating	NA	N.cm
Panel nut	100	N.cm
Clamp nut	100	N.cm
A/F clamp nut	7.000	mm

Mating life	500	Cycles mini
Weight	5.378	g

TOOLING

Part Number	Description	Hexagon
.	.	.
R282.271.000	CRIMPING TOOL	3.84
R282.235.037	CRIMPING DIES	3.84
R282.293.000	CRIMPING TOOL	-

OTHERS CHARACTERISTICS

-

ENVIRONMENTAL

Operating temperature	-65/+165	° C
Hermetic seal	NA	Atm.cm3/s
Panel leakage	NA	

Issue : 0323 A

In the effort to improve our products, we reserve the right to make changes judged to be necessary.

